

REV.	ECN NO.	DESCRIPTION	DATE	DESIGN
A/0	/	INITIAL RELEASE	2011-03-15	LH
A/1	/	CHANGE TOOLING	2015-1-23	LH

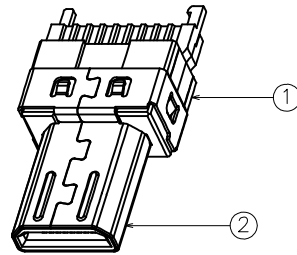

A0111019-XXX-H

HDMI SERIES	R:ROHS
SOLDER TYPE	H:HALOGEN FREE
PLUG	SEE TABLE A
NUMBER OF POSITIONS	CONTACT PLATING:
	0:GOLD FLASH
	1:5u" Gold
	3:15u" Gold
	6:30u" Gold
	7:SPCEIAL Gold

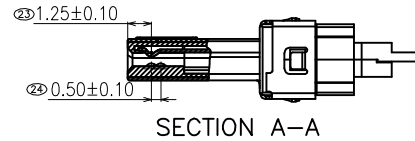
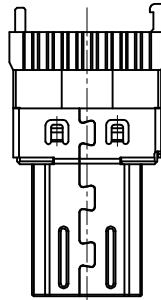
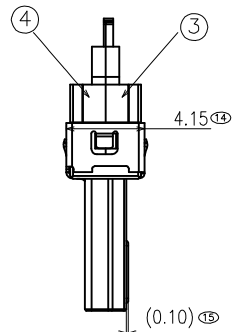
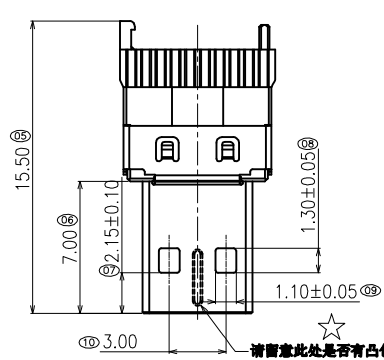

MATERIALS

- HOUSING : HI.-TEMP. PLASTIC. UL 94V-0, BLACK.
- CONTACT: COPPER ALLOY,T=0.15mm GOLD PLATED ON CONTACT AREA. UNDER NICKEL PLATED.
- SHELL: STAINLESS STEEL ,T=0.15mm.

MECHANICAL:

- Mating Force:44.1N Max.
 - Withdrawal Force:5-25N.
 - Durability:5000 cycles Min.
- SPECIFICATIONS**
- VOLTAGE--Max.[volts]: 40V AC(rms)
 - CURRENT--Max.[amps]: 0.5 A
 - Withstanding Voltage: 250V AC FOR 1 MINUTE.
 - Insulation Resistance [ohms]:100M次Min.

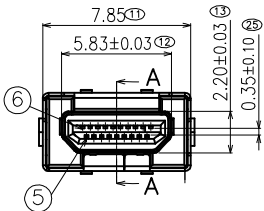

TABLE A

铁壳说明	电镀类别	成品料号	半成品说明	铁壳电镀料号
铁壳2条肋	铁壳镀金	A0111019-1A1-H	Molding半成品为普通型	
		A0111019-1A2-H	Molding半成品为加锡型	
	铁壳镀镍	A0111019-1A3-H	Molding半成品为普通型	
		A0111019-1A4-H	Molding半成品为加锡型	
铁壳3条肋	铁壳镀金	A0111019-1B1-H	Molding半成品为普通型	
		A0111019-1B2-H	Molding半成品为加锡型	
	铁壳镀镍	A0111019-1B3-H	Molding半成品为普通型	
		A0111019-1B4-H	Molding半成品为加锡型	

TABLE B

Molding半产品	Molding半产品料号说明	料号		
9PIN Molding	Molding半成品为普通型		H	F
	Molding半成品为加锡型			
10PIN Molding	Molding半成品为普通型			
	Molding半成品为加锡型			
⑥	HDMI D TYPE T2		PHOSPHOR BRONZE(C5210R-EH)	1SET
⑤	HDMI D TYPE T1		PHOSPHOR BRONZE(C5210R-EH)	1SET
④	HDMI D TYPE B2	SEE TABLE B	LCP	1PCS
③	HDMI D TYPE B1	SEE TABLE B	LCP	1PCS
②	HDMI D TYPE SHELL	SEE TABLE A	SUS301	1PCS
①	HDMI D TYPE HOUSING		LCP	1PCS
LTR	DRAW NAME	P/N No.	MATERAIL	QTY

BossConn Electronics

DIM.	TOL.	DIM.	TOL.	TITLE	PART NO.
X	± 0.30	X	± 2.00°	HDMI D TYPE PLUG CONN	HDD-M-CN01
XX	± 0.25	XX	± 1.00°		
XXX	± 0.15	XXX	± 0.50°	DWG NO.	P/N NO.
XXXX	± 0.10	XXXX	± 0.20°		
⊗ : CPK	DRAWN:	ANDY TIAN	2011.03.15	MATERIAL:	
	CHECKED:		2011.03.15	UNIT:	SCALE:
⊗ : PPK	APPROVAL:		2011.03.15	mm	SHEET.
				PROJ.	1/4
				REV.	A/1

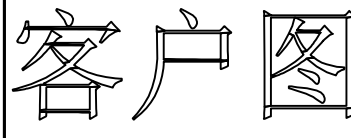

REV.	ECN NO.	DESCRIPTION	DATE	DESIGN
A/0	/	INITIAL RELEASE	2014-10-11	CYK

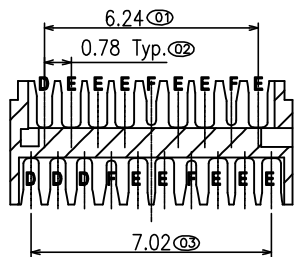

SECTION F-F

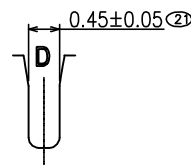

SCALE 2:1

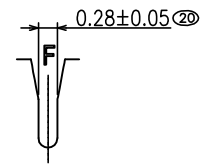

SCALE 2:1

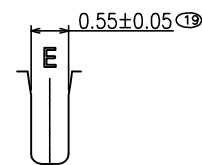

SCALE 2:1

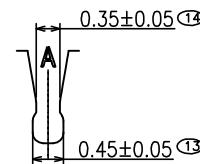
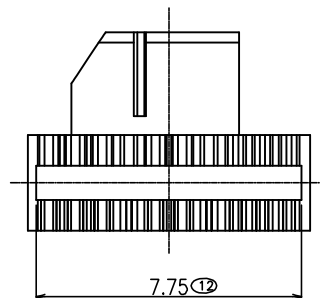
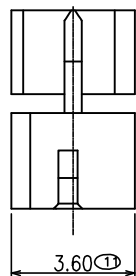
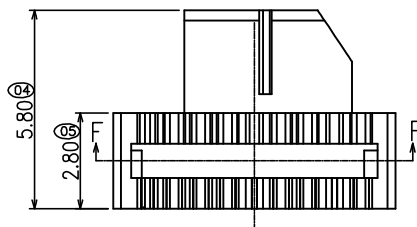

SCALE 2:1

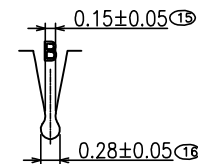

SCALE 2:1

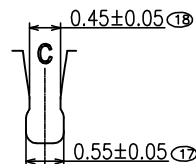

SCALE 2:1

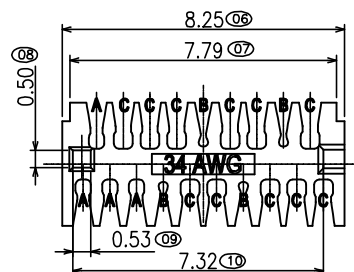

备注:
 1.材质:PA66+30%G.F , UL 94V-0.
 2.不可有不饱模, 起泡等外观不良.
 3.未标注R角为R0.15 max.,毛边0.05 max.

TABLE A

品名	料号	用料	备注
HDMI D TYPE1.4版34#黑色线夹		PA66+30%G.F 黑色无卤	符合HF
HDMI D TYPE1.4版34#本色线夹		PA66+30%G.F 本色无卤	符合HF
HDMI D TYPE1.4版34#黑色线夹		PA66+30%G.F 黑色	符合ROHS
HDMI D TYPE1.4版34#本色线夹		PA66+30%G.F 本色	符合ROHS



DIM.	TOL.	DIM.	TOL.	TITLE.	PART NO.
X	±0.30	X	± 2.00°	HDMI D TYPE 1.4版34AWG线夹	TABLE A
XX	± 0.25	XX	± 1.00°		DWG NO.
XJX	± 0.15	XJX	± 0.50°	DRAWN: C Y K 2014-10-11	
XJXX	± 0.10	XJXX	± 0.20°		CHECKED:
⊕	CPK	APPROVAL:		SCALE:	SHEET. 2/4
⊗	PPK			PROJ.	REV. A/0

REV.	ECN NO.	DESCRIPTION	DATE	DESIGN
A/0	/	INITIAL RELEASE	2010-12-25	夏 辉
A/1	ECN-20110624001	取消头部两侧挡板, 方便后制程成型	2010-06-24	

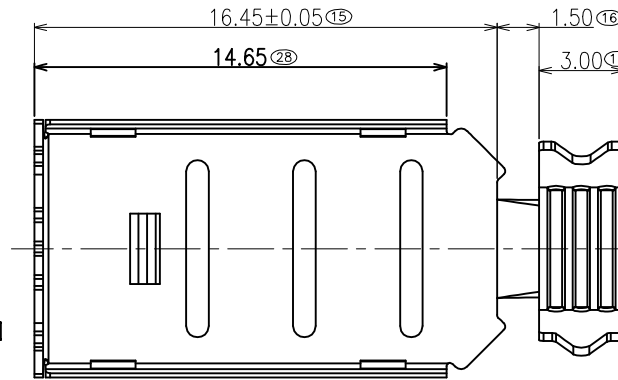
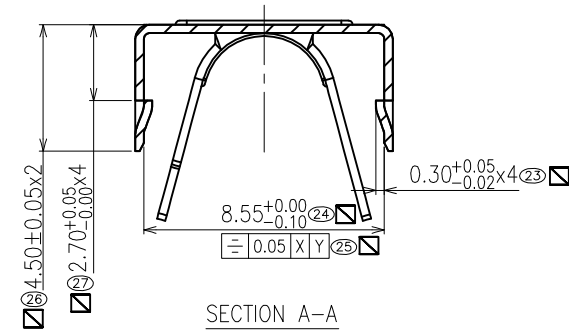
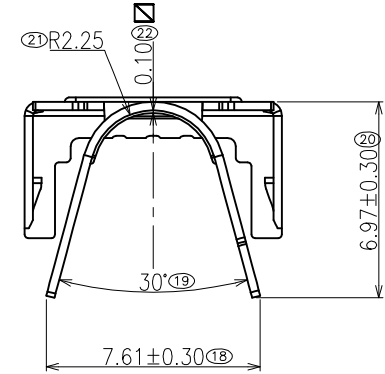
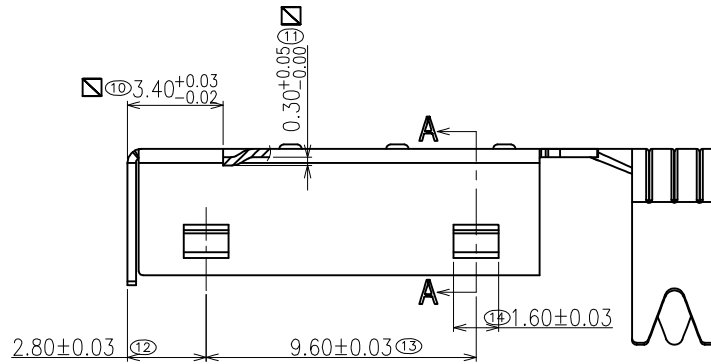
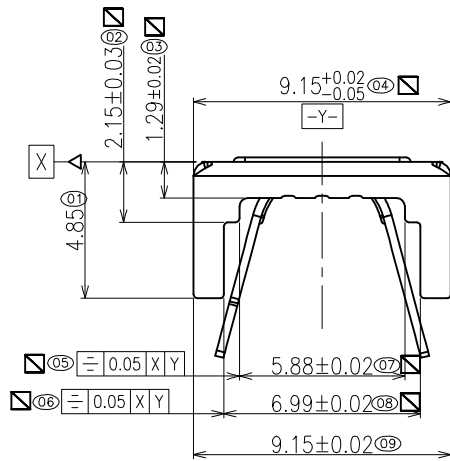

备注:

- 1.材质:SPCC, T=0.30MM
- 2.外观不可有压伤,严重的刮花,折弯处裂纹等不良.
- 3.未标注R角为R0.15 max.,毛边0.05 max.
- 4.产品冲制为散PIN.
- 5.标示"□"为重点检验尺寸
- 6.标示"XX"为FAI检验尺寸
- 7.标示"△"为修改设变尺寸

 **BossConn Electronics**

DIM.	TOL.	DIM.	TOL.	TITLE	PART NO.
X	± 0.15	X	$\pm 2.00^*$	HDMI D TYPE PLUG 上铁壳	HDD-M-CN01
XX	± 0.10	XX	$\pm 1.0^*$		
XXX	± 0.06	XXX	$\pm 0.5^*$	DWG NO.	P/N NO.
XXX	± 0.03	XXX	$\pm 0.2^*$		
⑯	CPK	DRAWN:		2011.06.24	MATERIAL: SPCC T=0.30MM
⑰	PPK	CHECKED:			UNIT: mm
⑱		APPROVAL:			SCALE: 1/1
					PROJ.  SHEET: 1/1
					REV. A/1

REV. A/0	ECN NO. /	DESCRIPTION INITIAL RELEASE	DATE 2010-12-1	DESIGN X.H
-------------	--------------	--------------------------------	-------------------	---------------

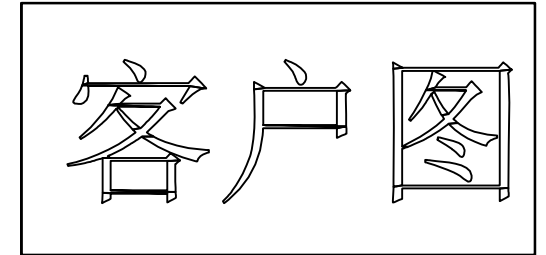
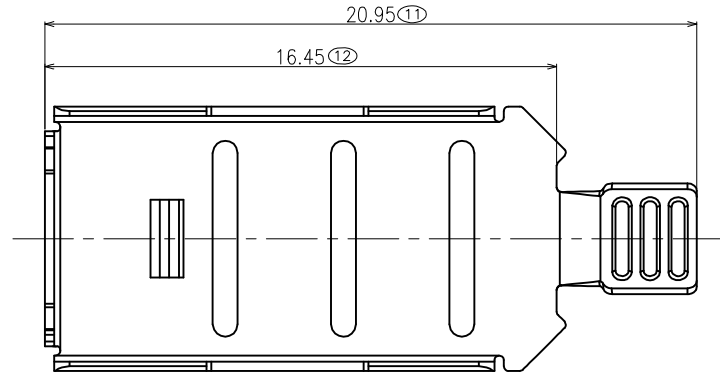
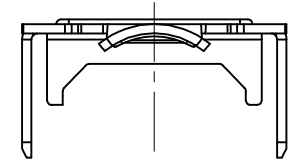
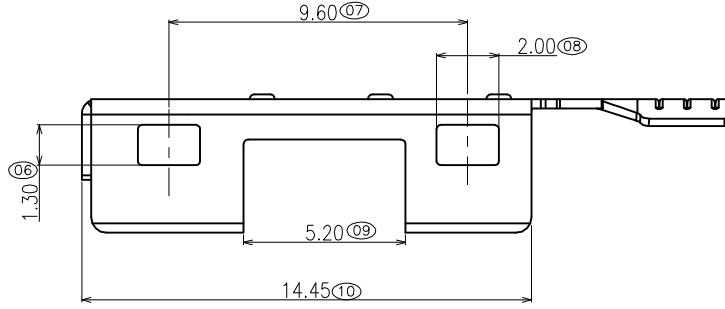
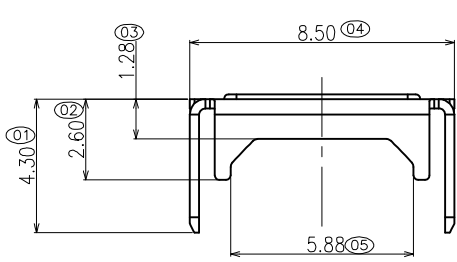

备注:

1. 材质: SPCC T=0.30MM

2. 电镀要求:

放大8倍无腐蚀, 氧化, 发黑, 剥落等不良现象.

需过油性封孔处理.

盐雾测试要求24H.

3. 料号说明:

-8XX

电镀材料
0: Au
8: Ni

电镀规格:

1: 100u"Cu, 100u"Ni
2: 150u"Cu, 150u"Ni

同类产品区别编号

 **BossConn Electronics**

DIM.	TOL.	DIM.	TOL.	TITLE	PART NO.
X	± 0.30	X	± 2.00*	HDMI D TYPE PLUG 下铁壳	HDD-M-CN01
XX	± 0.25	XX	± 1.00*		
XXX	± 0.15	XXX	± 0.50*	DWG NO.	P/N NO.
XXXX	± 0.10	XXXX	± 0.20*		
⑈ : CPK	DRAWN:		2010.12.1	MATERIAL:	
⑆ : PPK	CHECKED:			UNIT:	SCALE.
	APPROVAL:			mm	SHEET. 1/1
				PROJ.	REV. A/0